

## MAS SERIES - GEROLER TYPE



### Features:

Similar to Danfoss "OMS" Series

The MAS Series are GEROLER type 'Low Speed High Torque' Torqmotors. They feature tapered roller bearings on the output shaft which permit high radial and axial loads. The advanced valving design minimizes cross port leakage resulting in high volumetric efficiency and constant output speeds at varying pressures.

These Torqmotors are suitable for such applications as:

- Conveyor drives
- Winches
- Agricultural machinery
- Forestry machinery
- Cranes
- Sawmill equipment
- Elevators

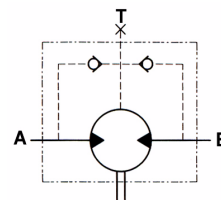
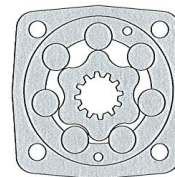

SAE 'A' 4 BOLT MOUNT/32mm KEYED SHAFT	
Part No.	
MAS-80-C	
MAS-100-C	
MAS-125-C	
MAS-160-C	
MAS-200-C	
MAS-250-C	
MAS-315-C	
MAS-400-C	

SEAL KIT	
Part No.	
SK-MAS	

The Above Options are our stock lines, other Shaft and mount option are available for quantity purchase ex the factory.

### PERFORMANCE FIGURES

Model	DISP CC/ REV	PRESSURE BAR		FLOW L/MIN		TORQUE				SPEED RPM		WEIGHT KG
		CONT.	INT.	CONT.	INT.	NM		IN/LBS		CONT.	INT.	
						CONT.	INT.	CONT.	INT.			
MAS-80	81	175	210	65	80	198	237	1751	2101	805	1000	10
MAS-100	100	175	210	75	90	244	293	2163	2595	746	900	10.3
MAS-125	125	175	210	75	90	307	368	2713	3256	598	718	10.5
MAS-160	160	160	210	75	90	340	469	3009	4148	465	560	11
MAS-200	200	150	180	75	90	395	490	3496	4337	373	447	11.4
MAS-250	252	140	175	75	90	450	535	3983	4735	298	360	11.9
MAS-315	315	120	140	75	90	541	630	4788	5576	236	290	12.5
MAS-400	397	100	120	75	90	580	690	5133	6107	187	230	13.5

## MAS SERIES - GEROLER TYPE

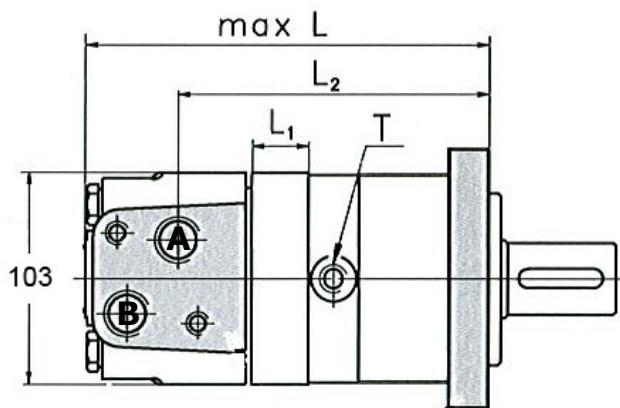
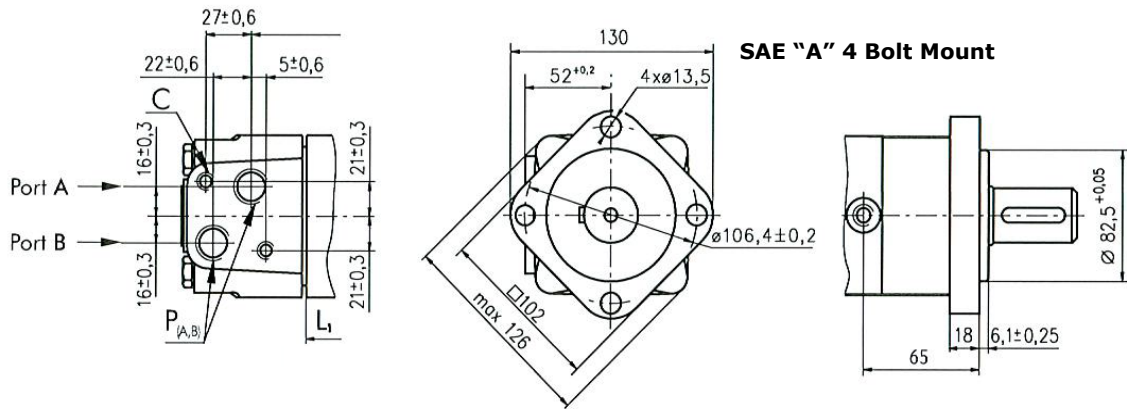

DIMENSIONS			
Model	L mm	L1 mm	L2 mm
MAS-80	168	16	124
MAS-100	172	20	128
MAS-125	177	25	133
MAS-160	183.5	31.5	139.5
MAS-200	192	40	148
MAS-250	202	50	158
MAS-315	214	62	170
MAS-400	226	74	182

Ports A & B = 1/2"BSPP

Drain Port T = 1/4"BSPP

Mount Hole "C" = 2 x M10-12mm deep

Case Drain required for Series connection

Flow in Port A = Clockwise  
Flow in Port B = counterclockwise

**C** Ø32 straight,  
Parallel key A10x8x45  
Max.Torque 770Nm

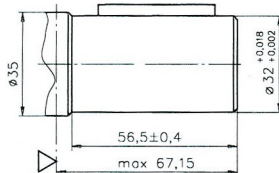

**CO** Ø 1 1/4" straight,  
Parallel key 5/16" x 5/16" x 1 1/4" BS46  
Max.Torque 770Nm

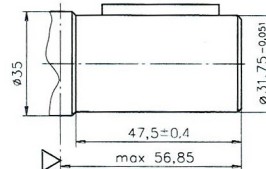

**SB** Ø 1 1/4" splined 14T, ANSI B92.1-1976 Norm  
Max. Torque 770Nm  
max 58.5

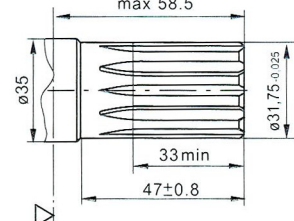

- NB:
- 1/ Intermittent operation values may occur for Max 10% of every minute.
  - 2/ Intermittent speed and intermittent pressure may not occur at the same time.
  - 3/ Recommended filtration to **ISO 4406:1999 Cleanliness Code 19/17/14**.
  - 4/ Recommended operation temperature range is 20°C to 55°C with a Max of 80°C for brief periods.
  - 5/ To assure optimum motor life, fill with fluid prior to loading and run for 1 hour at moderate load and speed.
  - 6/ The hydraulic fluid must be a Premium quality mineral based oil with anti wear additives.