



SLM Series

The **STREAMLINE MEDIUM DUTY**, or **SLM** hydraulic cylinder is a field proven design suitable for a vast majority of medium duty applications. The internally screwed front cap in conjunction with ports integrated within each end cap form the basis of the STREAMLINE design. These features, coupled with the use of high quality seals, make it a popular option for use within both the mobile and industrial markets.

Maximum working pressure = 207 BAR (3000 psi)

NB: For high pressure on long strokes, refer to our technical department for column strength of rods, etc.

High pressure T-seals on pistons and non-standard rods and strokes are available upon request.

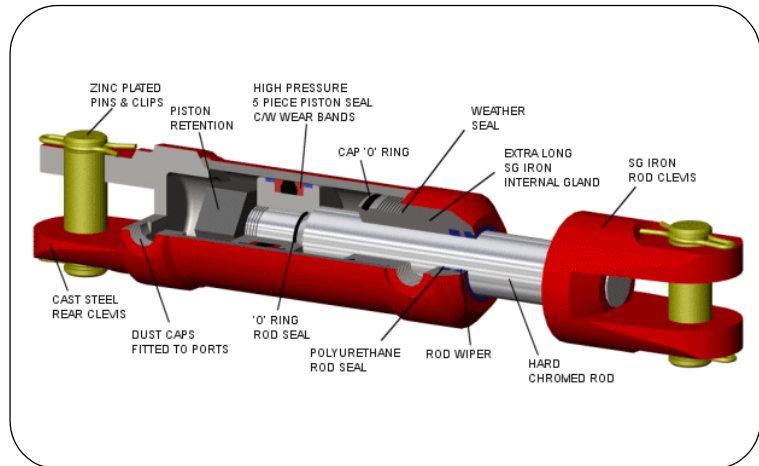

NB: To complete the part number, replace ** with the stroke length, i.e. 8" = 08.

Part No.	BORE	ROD	PORT	PIN	A	B	C	D	E	F	G	H	I	J	K	L	M	N
SLM15**	1.5"	7/8"	9/16"	3/4"	241	70	38	25	25	51	94	38	23	48	23	48	61	62
SLM20**	2.0"	1.0"	9/16"	3/4"	241	70	38	25	25	51	94	38	23	48	23	48	61	62
SLM25**	2.5"	1.5"	3/4"	1"	311	109	45	30	30	59	114	48	28	62	27	62	81	76
SLM30**	3.0"	1.5"	3/4"	1"	311	109	45	30	30	59	114	48	28	62	27	62	90	76

