

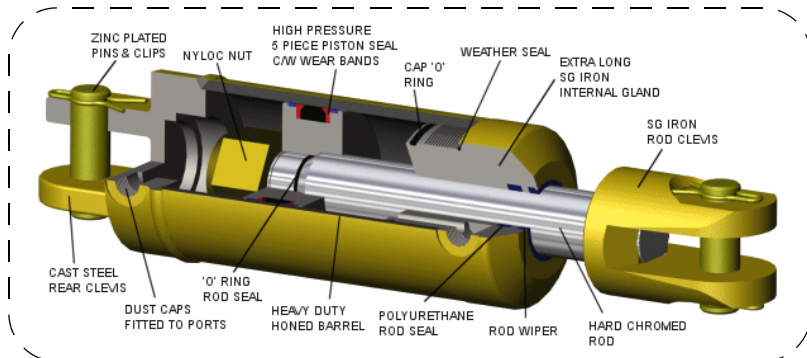

SLH Series

The **STREAMLINE HEAVY DUTY**, or **SLH** hydraulic cylinder is a robust design for medium to heavy-duty applications. The cylinder has a number of features which allows it to perform under demanding industrial type loading situations where a medium level of shock loading and pressure spiking may occur.



NB: To complete the part number, replace ** with the stroke, i.e. 8" = 08.

DIMENSIONS

Part No.	BORE	ROD	PORT	PIN	A	B	C	D	E	F	G	H	I	J	K	L	M	N
SLH25**	2.5"	1.5"	3/4"	1"	311	109	45	30	30	59	114	48	28	62	27	62	81	76
SLH30**	3.0"	1.5"	3/4"	1"	311	109	45	30	30	49	114	48	28	62	27	62	90	76
SLH35**	3.5"	1.75"	3/4"	1"	311	87	43	32	35	59	136	48	30	62	27	62	102	80
SLH40**	4.0"	1.75"	3/4"	1"	311	87	43	32	35	59	136	48	30	62	27	62	115	80
SLH45**	4.5"	2.0"	3/4"	1 1/4"	311	84	43	35	35	57	138	48	30	70	27	62	127	80
SLH50**	5.0"	2.0"	3/4"	1 1/4"	311	84	43	35	35	57	138	48	30	70	27	62	140	80

