

Sight Level Gauges

HL91 Sight Level Gauges are directly connected to the reservoir to check the level and temperature of the hydraulic fluid. There are 3 different mount dimensions available to suit your particular needs; 76mm, 127mm & 254mm. The external protective material is made of anodized aluminium to provide strong impact resistance while the central body is made of transparent polyamide.

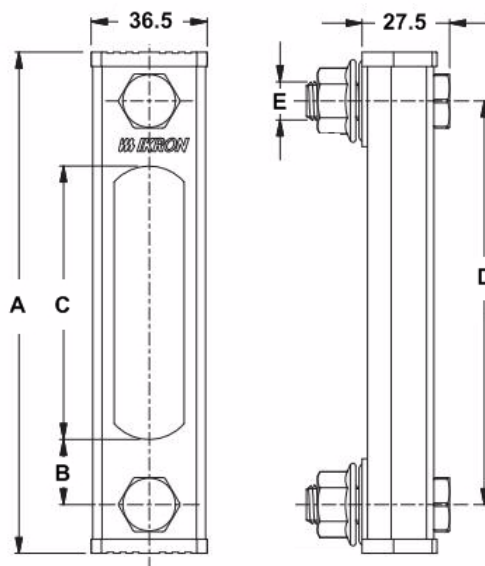

Part No.	With Thermometer	Dimensions				
		A	B	C	D	E
HL91-10-T1-N-B	no	106	17.5	41	76	M10
HL91-10-T1-T-B	yes	106	17.5	41	76	M10
HL91-20-T2-N-B	no	157	20.5	86	127	M12
HL91-20-T2-T-B	yes	157	20.5	86	127	M12
HL91-30-T2-N-B	no	284	20.5	213	254	M12
HL91-30-T2-T-B	yes	284	20.5	213	254	M12

OIL VISION PLUGS



Part No.	Thread BSPP
38.0427	3/8"
38.0428	1/2"
38.1070	3/4"
38.1072	1"
38.5159	1-1/4"
38.5176	1-1/2"

BREATHER - DIPSTICK



Part No.	Thread BSPP
Z290-0001	3/4"